



Promate[®] 240^S

Powerstation

Owner's Manual

INTRODUCTION

This product has been carefully engineered and manufactured to give you dependable operation. Please read this manual thoroughly before operating your new product as it contains the information you need to become familiar with its features and obtain the performance that will bring you continued enjoyment for many years. Please keep this manual on file for future reference.

TABLE OF CONTENTS

I. Important Safety Instructions.....	1
II. Specifications.....	3
III. Charging the Powerstation.....	4
IV. Battery.....	5
V. Operating as a Power Supply.....	6
1.1 Introduction.....	6
1.2 Operating Instructions.....	7
VI. Jumpstarting an Engine.....	9
VII. Maintenance Instructions.....	10
VIII. Moving and Storage Instructions.....	10
IX. Troubleshooting Guide.....	11
X. Service Information.....	13
Powerstation Exploded View.....	14

I. IMPORTANT SAFETY INSTRUCTIONS

1. To reduce risk of injury, charge only with the provided AC adaptor and charging cord. Other chargers may cause battery to burst causing injury to persons and damage.
2. Do not expose the Promate chargers to rain and moisture.
3. Use of accessories not recommended or sold by the manufacturer may result in a risk of fire, electric shock, or injury to persons.
4. To reduce the risk of damage to the cigarette lighter connector and cord, disconnect the cigarette lighter connector rather than the cord when disconnecting charger.
5. Make sure the cord is safe from being stepped on, tripped over, or otherwise subjected to damage or stress.
6. Do not operate the charger with damaged cord or cigarette lighter connector - replace it immediately.
7. Do not operate the Powerstation if damaged any way; Report it immediately to an authorized Promate service provider or dealer.
8. Do not disassemble the Powerstation or its charger; ask help from a service or repair technician authorized by Promate. Incorrect reassembly may result in a risk of electric shock or fire.
9. To reduce risk of electric shock, unplug charger before attempting any maintenance or cleaning.
10. Always correctly orient the Powerstation in the upright position.
11. Do not expose the device to direct sunlight, high temperature (>35°C) or extreme cold (<0°C).
12. Keep it away from dust and dirt.
13. Warning – Risk of explosive gases.
 - a. Working in vicinity of a lead-acid battery is dangerous. Batteries generate explosive gases during normal battery operation. For this reason, it is of utmost importance that each time you use your Powerstation, you read this manual and follow the instructions exactly.
 - b. Do not expose the Powerstation or battery to fire or intense heat as it may explode.
14. Personal Precautions
 - a. Never smoke or allow a spark or flame in the vicinity of battery or engine.
 - b. Use the Powerstation on a 12-volt LEAD-ACID battery only. Do not connect to a 6-volt or 24-volt battery system. Use the DC outlet socket to operate 12-volt appliances equipped with a cigarette lighter plug.
 - c. If battery acid comes in contact with skin, rinse immediately with running water, then wash thoroughly with soap and water. If redness, pain or irritation occurs, seek immediate medical attention.
 - d. If battery acid comes in contact with eyes, flush eyes immediately - for a minimum of 10 minutes - seek immediate medical attention.
 - e. Never jump-start a frozen battery
 - f. This system is not designed to be used as a replacement for a vehicular battery. Do not attempt to operate a vehicle that does not have a battery installed.

15. Battery Jump-start Precautions

Warning – Follow these steps when jumpstarting a vehicle. A spark near battery may cause a battery explosion to reduce risk of a spark near battery or injury, follow precautions below.

- a. Always connect the external connection cable clamps to the car battery terminals prior connecting to the Powerstation. Never touch battery clamps together, this can cause dangerous sparks, power arcing and/or explosion.
- b. Jump-start procedures should only be performed in a safe, dry, well-ventilated area.
- c. When using this unit in proximity to the vehicle's battery and engine, stand the unit on a flat, stable surface, and be sure to keep all clamps, cords, clothing and body parts away from moving vehicle components.
- d. Check polarity of battery posts. POSITIVE (POS, P, +) battery posts usually have a larger diameter than NEGATIVE (NEG, N, -) posts.
- e. Determine which post of battery is grounded (connected) to the chassis. If the negative post is grounded to chassis, (as in most vehicles), see (f). If positive post is grounded to the chassis, see (g).
- f. For negative-grounded vehicles, connect POSITIVE (RED) clip from jump-start cable to POSITIVE (POS, P, +) ungrounded post of battery. Connect NEGATIVE (BLACK) clip to vehicle chassis or engine block away from battery. Do not connect clip to carburetor, fuel lines, or sheet-metal body parts. Connect to a heavy gauge metal part of the frame or engine block.
- g. For positive-grounded vehicle, connect NEGATIVE (BLACK) clip from jump-start cable to NEGATIVE (NEG, N, -) ungrounded post of battery. Connect POSITIVE (RED) clip to vehicle chassis or engine block away from battery. Do not connect clip to carburetor, fuel lines, or sheet-metal body parts. Connect to a heavy gauge metal part of the frame or engine block.
- h. When disconnecting cables, FIRST disconnect the External Battery Connection Terminal from the Powerstation, THEN the black negative clamps (-) and then the red positive clamp (+), in that order
- i. Store in a cool, dry place and keep out of reach of children.
- j. Final jump-start Cautions
 - i. Vehicles that have on-board computerized systems may be damaged if vehicle battery is jump-started. Before jump-starting, read the vehicle's owner's manual to confirm that external starting assistance is advised.
 - ii. Excessive engine cranking can damage a vehicle's starter motor. If the engine fails to start after the recommended number of attempts, discontinue jump-start procedures and look for other problems that may need to be corrected.

II. SPECIFICATIONS

GENERAL SPECIFICATIONS:

Dimension(cm): 27.3 x 26 x 29.8

Gross Weight: 12 kgs

Output:

12V DC socket (max. 11 Amp)

12V DC Jack x 2 (total max. 1 Amp)

5V 2.1A USB port x 3 (Low voltage shut down 10V \pm 0.3V)

220V AC power inverter 400Watt (Low voltage shutdown 9V \pm 0.3V)

External battery connection for jumpstarting

Work light:

5 X LEDs work-light (Low voltage shut down 10V \pm 0.3V)

Charging:

Car – AC/DC charging port

AC – AC/DC charging port

Solar charging port

Built-in Battery: 12V, 24Ah valve regulated lead acid – AGM type battery

INVERTER SPECIFICATIONS:

Output Power Continuous: 400W Operating

Voltage: DC 11-14.5V

AC Output Voltage (RMS Meter): 220V \pm 10%

Output Wave Form: Filtered Modified Sine Wave Low

Battery Alarm: DC 10.3V \pm 0.3V

Low Battery Shut Down: DC 9V \pm 0.3V

Frequency: 60 Hz \pm 3

Efficiency: 85%

No Load Current Draw: < 0.65A

Over Temperature Protection: 100°C \pm 10%

LOCATION OF CONTROL

1. Rubberized handle
2. Digital display
3. Display button
4. AC/DC charging port
5. Solar charging port
6. 2 x 12 DC jack
7. 12V DC socket
8. 3 x USB port
9. Power inverter ON / OFF switch
10. USB power ON / OFF switch
11. LED work light ON / OFF switch
12. External battery / jumpstarting connection
13. 2 x 220V AC outlet
14. 5 x LED work-light



III. CHARGING THE POWERSTATION

NOTE: Powerstation must be fully charged for 24 hours before first use. Failure to do so may permanently damage battery.

TO READ THE POWERSTATION'S BATTERY VOLTAGE / INVERTER STATUS

1. Press the "ON" switch button of the power inverter
2. Press Display button to read the Power Inverter / Battery
Voltage Status "VAC" – Output AC Voltage
"Hz" – Output AC frequency
"Watt" – Power consumption of the device
"VDC" – Battery voltage of Powerstation
3. Recharge the unit when "VDC" reads < 12V
4. Switch Power inverter to "OFF" before recharging the unit.

CAUTION

This unit has a maintenance free, built-in sealed lead acid battery. Although the Powerstation arrives partially charged from the factory, it must be fully charged for 24 hours before first use, even if the digital meter indicates "VDC" battery voltage >12.8V, the battery is full. This initial charge pre-conditions of the battery are necessary. Failure to follow this procedure may permanently damage the battery.

CHARGING WITH AC ADAPTOR

1. Keep all power on/off switches in OFF position while charging.
2. Completely charge your Powerstation before using it for the first time.
3. Press display button to check battery voltage "VDC", if battery voltage reads <12V, it is necessary to recharge the Powerstation immediately for smooth running.
4. Before recharging from an AC outlet, be sure the source is right. (i.e., 110 volts or 230 volts)
5. Use only the chargers provided with unit.
6. Plug the AC charging cord into any standard wall outlet and the other end into the AC/DC charging input socket.
The RED LED will illuminate which indicates the unit is charging and will turn green when unit is fully charged.

First time charge:24 hours

Recharge and subsequent charges:UNTIL CHARGING LED LIGHT TURNS GREEN

CHARGING WITH DC ADAPTOR

Due to safety circuits built into the input-charging jack, DC charging through this port will not fully charge the battery.

1. Keep all power switches in OFF position while charging.
2. Insert DC adapter plug into charging port of Powerstation and the other end into the cigarette lighter socket of

your vehicle. The RED LED will illuminate which indicates the unit is charging. Vehicle should be running for full charging to take place.

NOTE: This method allows battery to be topped up during a journey but may not fully charge the unit. Disconnect charging cord before turning off engine. NEVER leave vehicle running in an enclosed or poorly ventilated space.

CHARGING WITH SOLAR PANEL

1. Keep all power switches in OFF position while charging.
2. Select a solar panel with 100-Watt maximum output
3. Connect the solar panel to the solar charging port of Powerstation. The RED LED will illuminate which indicates the unit is charging and will turn green when unit is fully charged.

CHARGING TIPS AND WARNINGS

- Keep battery charged, ready for emergencies. Unlike some rechargeable batteries, frequent charging will not harm and in fact, will improve the performance of the internal battery.
- Recharge battery as soon as possible after each use to prolong battery life.
- Frequent heavy discharges between recharging will reduce battery life.
- Do not leave the Powerstation in a total discharged state for an extended period of time as this can cause battery failure.
- All lead acid batteries suffer from self-discharge over time, especially under extreme temperatures.
- Store in a cool dry place.
- RECHARGE EVERY MONTH WHEN NOT IN USE.
- Do not continuously charge the Powerstation for more than 20 hours.
- Use only the charging adaptors provided with this unit.
- DO NOT OPERATE THE UNIT WHILE CHARGING.

IV. BATTERY

CHECKING THE BATTERY STATUS

Press the Display button.

1. > 12.5 VDC indicates full charge
2. < 12 VDC indicates it should be charged as soon as possible. It will be able to operate the AC appliance, LED light, phone accessories, and most 12 Volt Accessories for a limited time but will be inadequate for the boosting function. Take care not to let the battery drain completely as it may damage the battery.
3. <11V "VDC" indicates the battery is low and usage must be discontinued immediately. Recharge battery as soon as possible and before further use.

BATTERY SPECIFICATION

This unit is equipped with a 2 x 12 VDC 12 Amp-hour maintenance free, sealed lead acid rechargeable battery, which has a normal life expectancy of up to 500 charging cycles and will give many years of dependable service if properly cared for following the directions above. In the event that the battery needs replacement in the future, the unit will need to be opened up; this service should be performed by a qualified service technician. Replacement batteries may be purchased from an electrical supply store. Old batteries should be disposed of properly and safely. Please contact your local solid waste authority for recycling information.

EXTERNAL BATTERY CONNECTION

1. It is possible to increase the operating power of the Powerstation by connecting it to an external 12V lead acid battery with external battery connection cable.
2. It can be used as a jump-start system during road emergencies.

V. OPERATING AS A POWER SUPPLY

The Promate 240s is capable of supplying power for 220V AC household devices and 12V DC devices up to the rated capacity of the unit. The length of time the product will operate depends on the condition of the battery and the current draw of the appliance. Low wattage appliances can be operated for several hours while higher wattage products will operate for less time.

220V AC SOCKET

1.1 Introduction

The Powerstation is equipped with a 400-Watt power inverter that converts the power from the internal battery to standard 220 Volt AC household power. The Power Inverter supplies 400 watts of continuous power with 800 watts of surge power. When you turn on an appliance or a tool that operates using a motor or tubes, it requires an initial surge of power to start up. This surge of power is referred to as the “starting load” or “peak load”. Once started, the tool or appliance requires less power to continue to operate. This is referred to as the “continuous load” in terms of power requirements.

You will need to determine how much power your tool or appliance requires to start up and how much power it requires for continuous running. Power consumption is rated either in wattages (watts) or in amperes (amps).

Multiply: $AMPS \times 220$ (AC voltage) = WATTS

This formula yields a close approximation of the continuous load of your appliances.

Multiply: $WATTS \times 2$ = Starting Load

This formula yields a close approximation of the starting load of your appliances.

Most often the start-up load of the appliance or power tool determines whether the inverter has the capability to power it.

CAUTION

Know the wattage requirement of your appliances. Use only those appliances that do not exceed the capacity of this unit.

The output waveform of this inverter is a MODIFIED SINE WAVE. It has a total harmonic distortion of 28% and maximum single harmonic of 18%. If you choose to measure the AC output voltage, you must use a TRUE RMS VOLTMETER such as a Fluke 8060A, Fluke 87, Triplet 4200, Beckman 4410 or any "True RMS" multimeter. Using any other type of voltage measuring device will result in an AC voltage reading of 20 to 30 volts lower than the rated value.

CAUTION

Do not use this Powerstation with equipment that can be damaged by the inverter's modified sine wave output (non-sinusoidal) including (but not limited to) appliances with speed controllers (such as power tools). Metal halide arc (MHI) lights can be damaged.

NOTE: If you are unsure about powering any device with the inverter, contact the equipment manufacturer to determine the appliance's compatibility with the modified sine wave (non-sinusoidal) AC waveform.

1.2 Operating Instructions

Before using the inverter, ensure that the battery of your Powerstation is fully charged. Place the inverter power switch in the on position. The digital display will come on to confirm that the AC outlet is powered. If the AC product you are operating has a power switch, we recommend that it be put in the "OFF" position. Plug product into the AC outlet and proceed to use according to the directions on the product. The Powerstation will operate most devices rated up to 400 watts. The AC Power supply is equipped with a low battery alarm and an automatic shutdown feature to protect the unit if the battery power drops below the safe recharging level. If the alarm sounds while you are operating an AC product, shut off the device immediately and discontinue use until the Powerstation battery can be recharged. Switch inverter "OFF" and disconnect the AC product. Recharge battery as soon as possible and before further use. If you ignore the warning alarm, the power supply will automatically shut down and your AC product will instantly lose power. The AC power supply function is also protected against overloads and overheating. If either of these conditions should occur, the power inverter will shut down automatically.

a. Operating a TV

When operating a TV monitor or TV/DVD combo, please note that picture tubes have a degaussing coil, which uses a high initial surge of power to light up the screen from a "cold start". If the TV does not start up on the first try, switch the TV on every 2-3 seconds until the screen comes on. Some screens may take 2-5 tries before starting.

b. Operating with an extension cord

We recommend that you use an extension cord no longer than 100 ft. between the AC output and AC appliance. A longer cord may result in reduced output.

c. Extended operating with an external battery.

You can extend the Powerstation operating time by connecting it to a larger external 12 VDC battery.

Ensure that the spare battery is 12 VDC. Ensure correct polarity connection of the red positive (+) clip of the cables to the red positive (+) terminal of the external battery by connecting the black negative (-) clip of the cables to the black negative (-) terminal of the external battery. Then, insert the other end of external battery connection terminal to the Powerstation for supplemental power.

CAUTION

Do not recharge Powerstation while it is connected to an external battery.

USB PORT

NOTE: Prior to connecting the accessory, make sure that the USB port ON / OFF power switch is in the OFF position. Accessory Connection (iPad, iPhone..., etc.)

1. Connect the USB interface cable (provided with the accessory) into the accessory and the Portable Powerstation USB port.
2. Press the USB Port On/Off switch of the unit to the ON position. Turn on the accessory for operation.
3. Press USB Port switch to OFF position when not in use.

NOTE: To avoid the built-in battery from being completely depleted from slow discharging in a period of time and if the Powerstation has not been recharged immediately, the battery will be damaged and cannot be recharged again.

12V DC JACK

The Powerstation is equipped with 2 x 12V DC jack and can be used to operate 12V DC devices (maximum total 1 Amp). Periodically check battery voltage status "VDC" during operation and discontinue use immediately, if battery condition falls to 11V. Recharge unit as soon as possible and before further use.

12V DC jack is protected by an internal circuit breaker to prevent damage to the unit in case the device has a short circuit or exceeds 1 AMP. If circuit breaker is tripped, disconnect the device and have it checked. Circuit breaker will automatically reset once it's cooled down. (approx. 15-20 minutes).

12V DC PORT

The Powerstation is equipped with an outlet socket and can be used to operate most 12-Volt auto accessories and appliances (11 AMP maximum) equipped with a cigarette lighter plug. Simply plug in appliance. NOTE: Socket is

live so appliance will be instantaneously powered. Length of time appliance will operate depends on the condition of battery and current draw of appliance. Periodically check battery voltage status “VDC” during operation and discontinue use immediately if battery condition falls to 11V.

Recharge unit as soon as possible and before further use.

12V DC PORT is protected by an internal circuit breaker to prevent damage to unit in case appliance has a short circuit or exceeds 11 AMPS. If circuit breaker is tripped, disconnect appliance and have it checked. Circuit breaker will automatically reset once it cools down (approx. 15-20 minutes). DO NOT PLUG A CIGARETTE LIGHTER INTO THE OUTLET OF THE POWERSTATION.

LED WORKLIGHT

1. Simply turn ON the LED work light by pressing the LIGHT button.
2. Turn OFF the LED work light by pressing again the LIGHT button.
3. Turn OFF while not in use.

VI. JUMPSTARTING AN ENGINE

CAUTION

1. Make sure all switches of the Powerstation are in “OFF” position. Powerstation must be fully charged to jump-start an engine. Do not attempt to jump-start an engine if the “VDC” reading of the Powerstation is < 12V when you press the display button as this could permanently damage the battery.
2. Turn off ignition and all accessories (lights, radio, heater, air-conditioning, etc.) in the vehicle with weak battery that will not start.
3. Place vehicle in park and set hand brake.
4. For maximum power, turn off all switches on your Powerstation and disconnect any accessories plugged into the 12 Volt power outlets.
5. Check that vehicle is negatively grounded (most vehicles).
6. Securely connect the external battery connection cable red positive clamp to the positive (+) terminal of the vehicle battery. Then, securely connect the black clamp to a grounding point on the vehicle such as the metal frame, as far away from the battery as possible. DO NOT connect it to the negative battery terminal. Make sure both clamps have good and correct polarity connection before connecting the other end of the External Battery Connection Terminal to the Powerstation.

NOTE: Do not place Powerstation where it could fall when vehicle starts up. Make sure that cables are routed away from motor fan or belts.

7. Start your vehicle.
8. Once vehicle starts, disconnect the external battery connection terminal from the Powerstation, black clamp, and then red clamp in that order. Restore cables and recharge unit at first opportunity.

NOTE: When starting vehicle, crank engine in 5-6 second bursts. If vehicle does not start-up within 2-3 attempts, allow the battery to cool for 3 minutes before attempting to start vehicle again. Retry only if battery condition is >12V.

BATTERY SAFETY

When the External Battery Connection Terminal is connected to the Powerstation, never allow the positive and negative booster clamps to come into contact with each other (or a common piece of metal) at any time. Otherwise, it will short-circuit the battery and it will cause explosion and damage to your car.

When jump-starting a vehicle, make sure that the positive and negative clamps are properly connected to the vehicle and battery. Failure to connect the clamps properly may cause sparking, an explosion or damage to the unit. Always wear eye protection when working with batteries.

If battery acid comes into contact with eyes, flush the eyes with water for at least 10 minutes. Seek medical attention immediately.

If skin or clothing comes into contact with battery acid, immediately wash the affected area with soap and water. Seek medical attention.

Be sure to remove all metal items (watches, necklaces, rings, etc.) before using the Jump-start System. Always turn OFF the Powerstation when not in use. Store in cool, dry place.

VII. MAINTENANCE INSTRUCTIONS

All batteries lose charge with time. AC recharge is recommended after every use or every three months when not in frequent use. Use the AC charger and charge for the recommended time.

If the unit gets dirty, gently clean the outer surfaces with a soft cloth moistened with a mild solution of water and detergent. Do not use solvents or other chemical cleaners. Periodically check the condition of charging adapters, connectors, and wires. Replace any components that may have become worn or broken. These parts are not serviceable. Do not open or disassemble. Service for Powerstation units is confined to replaceable parts only. All other servicing should be performed by a qualified service technician only.

VIII. MOVING AND STORAGE INSTRUCTIONS

Turn OFF all power switches of the Powerstation when not in use. Store in a cool, dry place.

Fuse Replacement – 12Volt adapter plug

This 12-volt plug is fitted with a 2A fuse in the tip. Should the fuse need replacing, unscrew end cap and replace with a new 2A fuse.

CAUTION

For continued protection against risk of fire, replace only with same type and rating of fuse.

WARNING! EXPLOSION HAZARD

Do not expose battery to fire or intense heat as it may explode. Battery contains acid: if case should become cracked, dispose of immediately taking adequate safety precautions to prevent injuries or damage to persons or property.

IX. TROUBLE SHOOTING GUIDE

Buzz in Audio Equipment

Some inexpensive stereo systems have inadequate internal power-supply filtering and may buzz slightly when powered by the

Powerstation. The best solution to eliminate the buzzing is to use an audio system with a good quality filter.

Television Interference

The Powerstation is shielded to minimize interference with TV signals. If TV signals are weak, you may see interference in the form of lines scrolling across the TV screen. Try one of the following suggestions to minimize or eliminate the interference:

- Use an extension cord to increase the distance between the Powerstation and the TV, antenna, and cables.
- Adjust the orientation of the Powerstation, television, antenna, and cables.
- Maximize TV signal strength by using a better antenna. Use a shielded antenna cable where possible.
- Try a different TV. Different models vary considerably in their susceptibility to interference.

AC Power Supply Problems

Problem	Possible Cause	Solution
AC product not operating	<ol style="list-style-type: none">1. AC product is drawing more than 400W2. AC product is rated at less than 400W, but the high starting surge has tripped the safety overload.3. Battery has discharged to $9V \pm 0.3V$	<ol style="list-style-type: none">1. Use an AC product with power rating less than 400W2. Use an AC product with a starting surge within 800W surge rating of the power station3. Turn the AC outlet off and recharge the power station
Overload shutdown	Appliance power requirements exceed the capability of the Powerstation	Unplug the appliance and confirm that the appliance's power requirement is 400W or less before attempting to restart the appliance.

Over temperature shutdown	Inverter has overheated due to poor ventilation or excessively warm environmental conditions.	Turn the AC Outlet On/Off switch off and allow Powerstation to cool for 15 minutes or more. Clear blocked fan opening or remove objects covering the unit. Move to a cooler environment.
Alarm sounds	4. Internal battery is nearly discharged $10.3V \pm 0.3V$ 5. If you ignore this warning, the Powerstation will automatically shut down when the battery reaches $9V \pm 0.3V$.	Recharge the Powerstation
Run time is less than expected	Internal battery was not fully charged. AC product power consumption is higher than expected. Battery has been damaged.	Recharge using AC charger until battery status read $>12.8V$ Check AC product power or wattage rating (or current draw for 12V DC appliances). Note: Start up load will affect running time of appliance.

Jumpstart Problems

Problem	Possible Cause	Solution
The engine being boosted will not start	Powerstation battery is not fully charged	Recharge the battery.
	The engine condition is poor	Have the engine serviced.
	The engine start capacity exceeds the booster capability of the Powerstation	

Charging Problems

Problem	Possible Cause	Solution
Charging Status light is off when AC charger is connected	NO AC power at the AC wall outlet AC charger is faulty	Ensure power is available at the AC wall outlet. Replace the AC charger

WARNING! ELECTRIC SHOCK HAZARD

Do not remove the housing or disassemble the Powerstation except to replace the internal battery. The Powerstation does not contain any internal user-serviceable parts and attempting to service the unit yourself could result in electric shock or burn.

X. SERVICE INFORMATION

HOW TO ORDER REPLACEMENT PARTS

Even quality-built equipment such as the generator you have purchased will need occasional replacement parts to maintain its good condition over the years.

To order replacement parts and consumable parts, please contact Promate Service (details below) and be ready with the following information:

1. Model No., Serial No. and all specifications that are shown on the Model No./Serial No. plate.
2. Part number or numbers as shown in the Parts List section.
3. A brief description of the trouble with the generator.

LIMITED WARRANTY

Warranty Coverage: Powertech Asia Pacific Inc., (the Company) warrants to the original retail customer that it will repair or replace, free of charge, any parts found by the Company or its authorized service representative to be defective in material or workmanship. This warranty covers the cost of replacement parts and labor for defects in material or workmanship.

Not Covered:

- Shipping/Handling charges for sending the product to the Company or its authorized service representative for warranty service. Shipping/Handling repaired or replaced products back to the customer; these charges must be borne by the customer.
- If a separate operator's manual and engine warranty from the engine manufacturer is included with this product, only that warranty will apply to the engine.
- Damage caused by abuse, accident, the effects of corrosion, erosion and normal wear and tear.

- Warranty is void if the customer fails to install, maintain and operate the product in accordance with the instructions and recommendations of the Company set forth in the owner's manual, or if the product is used as rental equipment.
- The Company will not pay for repairs or adjustments to the product, or for any costs of labor performed without the Company's prior authorization.
- Consumable parts such as battery, spark plugs, and air cleaner.

Warranty Period: One (1) year from the date of purchase on products used solely for consumer applications; if a product is used for business or commercial applications, the warranty period will be limited to ninety (90) days from the date of purchase.

For warranty service, the customer must provide dated proof of purchase and must notify the Company within the warranty period.

EXCLUSIONS AND LIMITATIONS: THE COMPANY MAKES NO OTHER WARRANTY OF ANY KIND, EXPRESS OR IMPLIED. IMPLIED WARRANTIES, INCLUDING WARRANTIES OF MERCHANTABILITY AND OF FITNESS FOR A PARTICULAR PURPOSE, ARE HEREBY DISCLAIMED. THE WARRANTY SERVICE DESCRIBED ABOVE IS THE EXCLUSIVE REMEDY UNDER THIS WARRANTY; LIABILITY FOR INCIDENTAL AND CONSEQUENTIAL DAMAGES IS EXCLUDED TO THE EXTENT PERMITTED BY LAW.

This warranty gives you specific legal rights, and you may also have other rights which vary from state to state. Some states do not allow a disclaimer of implied warranties or the exclusion or limitation of incidental and consequential damages, so the above disclaimers and exclusions may not apply to you.



CONTACT THE POWERTECH Asia Pacific Inc.,

PRODUCT SERVICE DEPARTMENT AT (02) 8 638 1569 | (+63) 9338373922
service@powertechasiapacific.com www.facebook.com/PromateServicePH/

Powerstation Exploded View Model:

Promate 240s

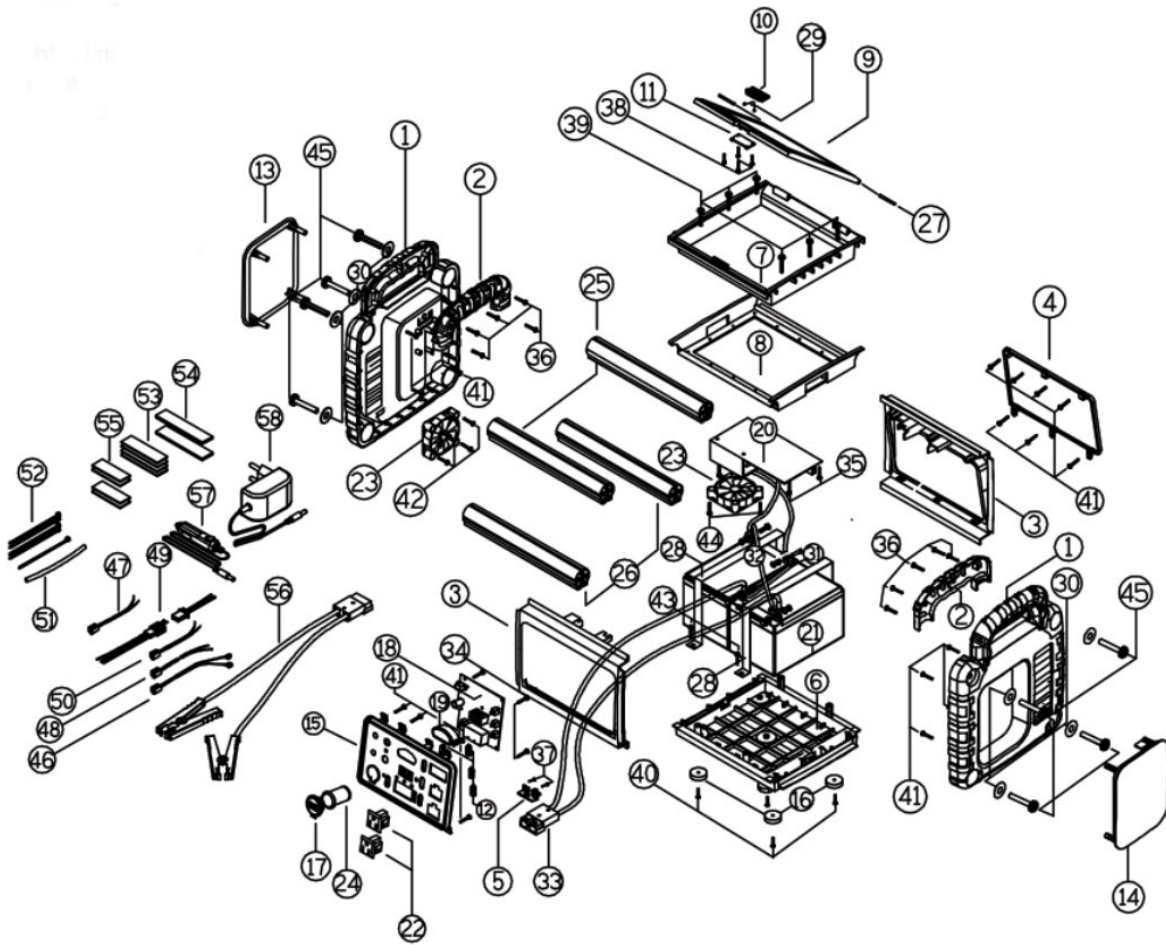

NO.	DESCRIPTION	NO.	DESCRIPTION	NO.	DESCRIPTION
1	Left and right side covers	21	12VDC Lead Acid Battery 12 AH x 2	41	Screw PWA3*10
2	Handle cover	22	AC socket	42	Screw PWA3*25
3	Front and rear panel bracket	23	Cooling fan	43	Screw PA3.5*15
4	Rear panel	24	Cigarette lighter cylinder	44	Screw BM3*16
5	Battery charger socket tablet	25	Round aluminum tube	45	Screw TM6*20 D12
6	Bottom cover	26	Special shaped aluminum pipe	46	Power line
7	Middle cover	27	Axel	47	Cigarette lighter line
8	Middle cover bracket	28	Battery pressing plate	48	Light switch line
9	Top cover	29	Push spring	49	Inverter switch line
10	Top cover push	30	Washer	50	Inverter data line
11	Push cover	31	Parallel connection battery red line	51	Heat shrinkable tube
12	Switch button	32	Parallel connection battery black line	52	Cable ties
13	Left side cover panel	33	Battery charger socket line	53	Double sided tape
14	Right side cover panel	34	Screw BA2.3*8	54	Single-sided adhesive tape
15	Front panel	35	Screw BA3*8	55	Single-sided adhesive tape
16	Rubber feet	36	Screw BA3*12	56	Battery charger clip wire
17	Plastic cover of cigarette lighter	37	Screw BA3.5*20	57	DC charger
18	PCB panel	38	Screw KA2*5	58	AC adapt
19	LED lamp transparent cover	39	Screw KA3*10		
20	Inverter board (PCB)	40	Screw PWT3*8		